

Before you begin to assemble your new piece of furniture please check to ensure all parts and fittings have been supplied. Follow all instructions closely as deviation from them may void warranty and present possible safety risk. It is recommended that assembly is done on a soft surface, like carpet, to avoid damage. CARE INSTRUCTIONS: Periodically re-tighten all fasteners. TOOLS REQUIRED: Allen key (provided), screwdriver and hammer. Some packs may come with timber of a different colour to the model purchased. These pieces are for packing purposes only.

If you experience any problems with your new purchase please phone our Customer Service staff on (FREE CALL PHONE / FAX) 1800 029 715

Please keep last page of the instruction for warranty information.

CLEANING AND MAINTENANCE: Do not use solvent or alcohol based cleaners on this unit. To clean unit, we recommend using a warm damp cloth to wipe over surfaces.

PARTS CHECKLIST

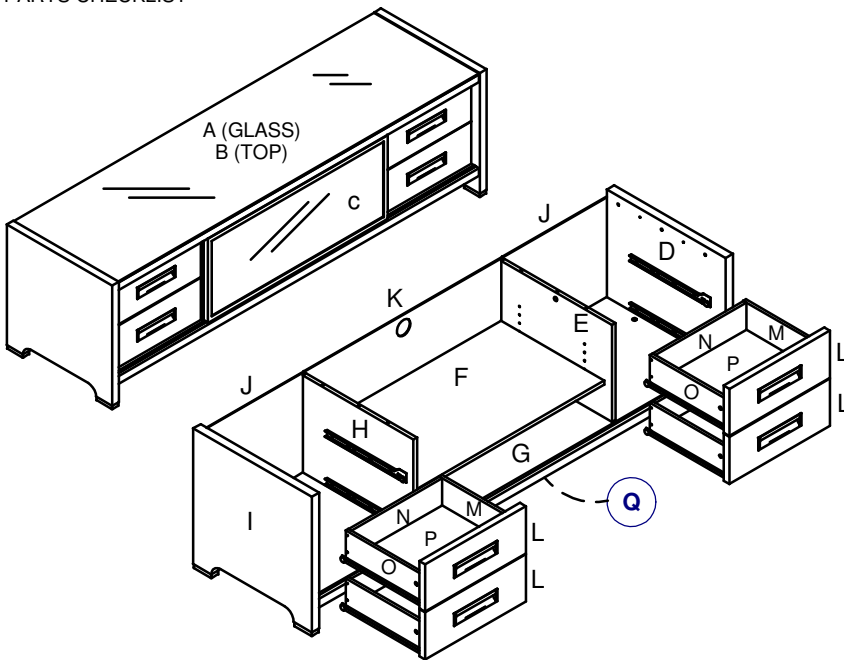





CODE	PART	SIZE	QTY
A	GLASS TOP	1793 x 520	1
B	TOP	1795 x 520	1
C	GLASS DOOR	893 x 362	1
D	RIGHT SIDE	519 x 524	1
E	RIGHT PARTITION	371 x 489	1
F	ADJ SHELF	859 x 457	1
G	BASE	1793 x 520	1
H	LEFT PARTITION	371 x 489	1
I	LEFT SIDE	519 x 524	1
J	SML BACK PANEL	480 x 395	2
K	LGE BACK PANEL	876 x 395	1
L	DRAWER FRONT	445 x 180.5	4
M	RIGHT DRW SIDE	336 x 120	4
N	DRAWER BACK	401 x 120	4
O	LEFT SIDE	336 x 120	4
P	DRAWER BASE	413 x 328	4
Q	SUPPORT	295 x 85.5	1

FITTINGS CHECKLIST

CODE	FITTING	DESCRIPTION	QTY
50-001		32mm WOODEN DOWEL	16
50-007		SHELF SUPPORT	4
50-009		4mm ALLEN KEY	1
50-010		EURO SCREW	16
50-011		SCREW 6g x 1/2"	16
50-012		CONFIRMAT CAP	2 / 2
50-015		MINIFIX CAM	10
50-016		MINIFIX METAL DOWEL	18
50-026		NAILS	2
50-043		HI LO SCREW	24
50-136		MICROFIX CAM	8



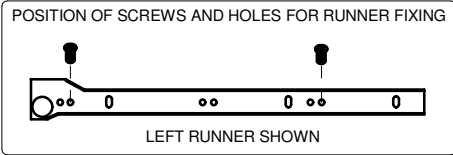
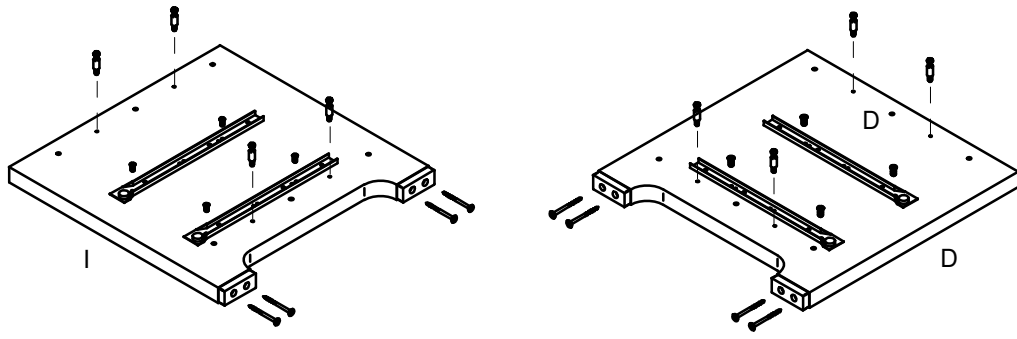

CODE	FITTING	DESCRIPTION	QTY
50-140		CAM CAP	2 / 2
50-301		DRAWER SUPPORT	4
50-421		CONFIRMAT 70mm	6
50-425		BUMP STOP	6
50-485		SCREW M4 x 15mm	8
51-005		350mm RUNNER	4 set
51-183		NAIL ON FOOT	2
51-488		HANDLE RECESSED	4
51-511		METAL FOOT	4
80-001		GLUE	2

STEP 1: PREPARE LEFT AND RIGHT SIDES

- 50-016 x 8 
- 50-043 x 8 
- 50-010 x 8 
- 51-005 x 4 
- 51-511 x 4 







STEP 2: PREPARE LEFT PARTITION

- 50-001 x 2 
- 50-015 x 1 
- 50-010 x 4 
- 51-005 x 2 



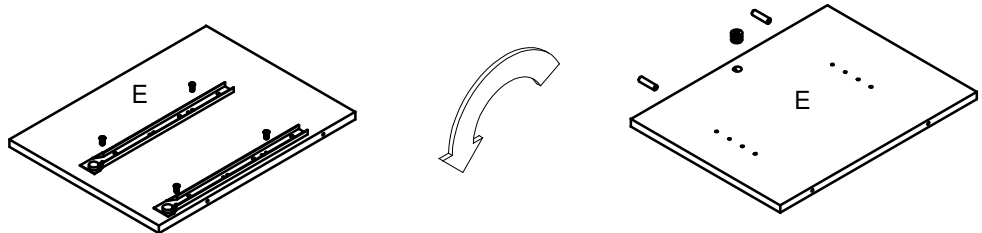

STEP 3: PREPARE RIGHT PARTITION

- 50-001 x 2 
- 50-015 x 1 
- 50-010 x 4 
- 51-005 x 2 



STEP 4: PREPARE TOP

- 50-001 x 6 
- 50-015 x 4 
- 50-016 x 2 

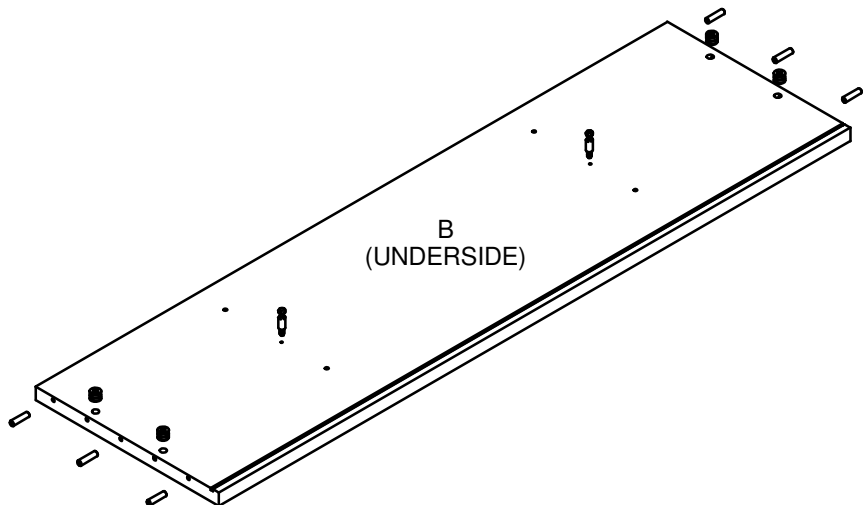

STEP 5: PREPARE BASE

50-001
x 6

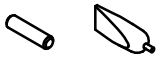

50-015
x 4

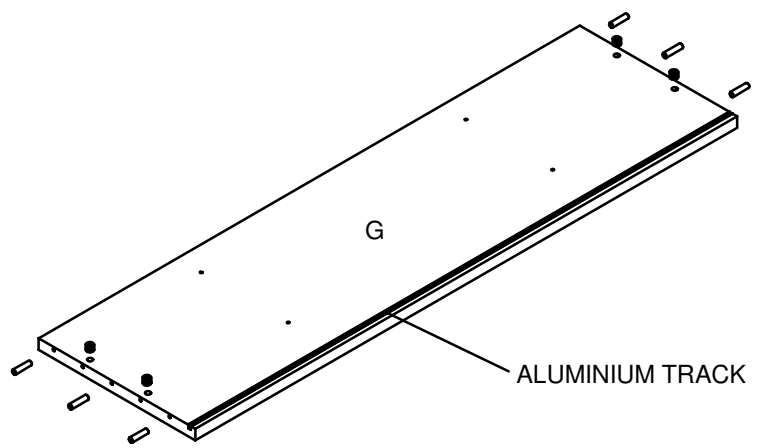

ALUMINIUM TRACK

STEP 6: ATTACH PARTITIONS AND BASE

50-421
x 4



TURN CAM (50-015)
CLOCKWISE TO LOCK

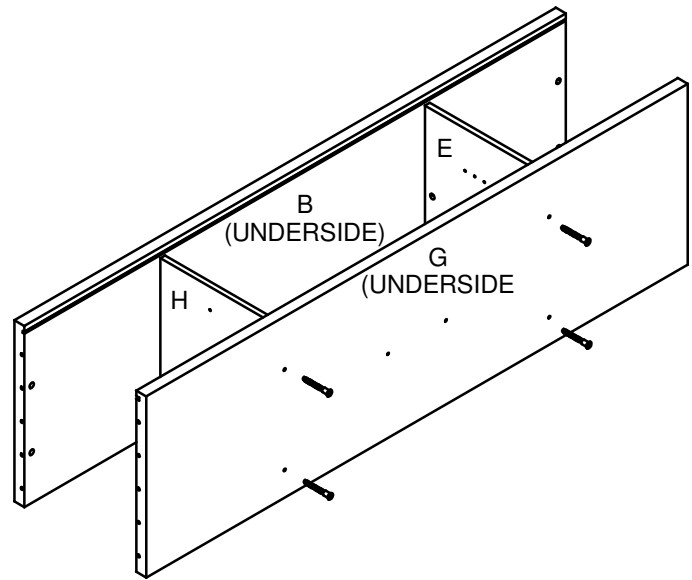

STEP 7: ATTACH LEFT SIDE, RIGHT SIDE AND SUPPORT

50-012
x 2



50-421
x 2



50-183
x 2



TURN CAM (50-015)
CLOCKWISE TO LOCK

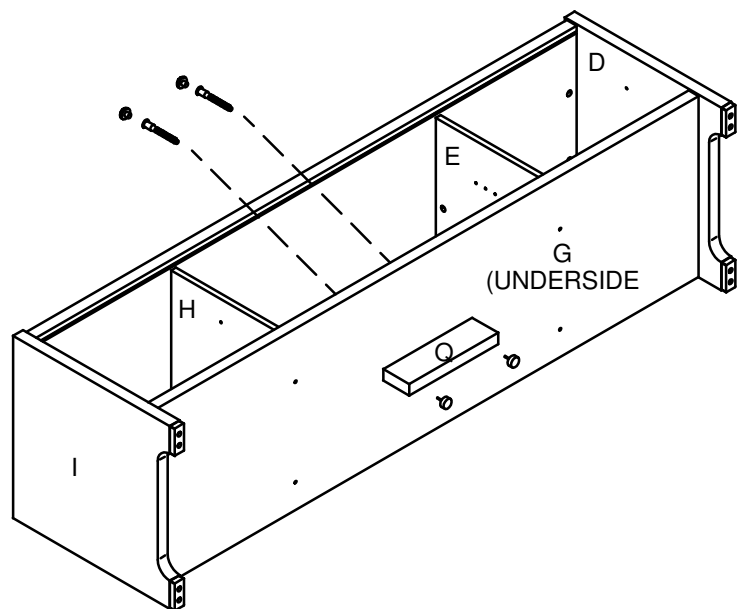

STEP 8: STAND UNIT UP, INSERT ADJUSTABLE SHELF, AND ATTACH BACK PANELS

- 50-007
x 4
- 50-026
x 2

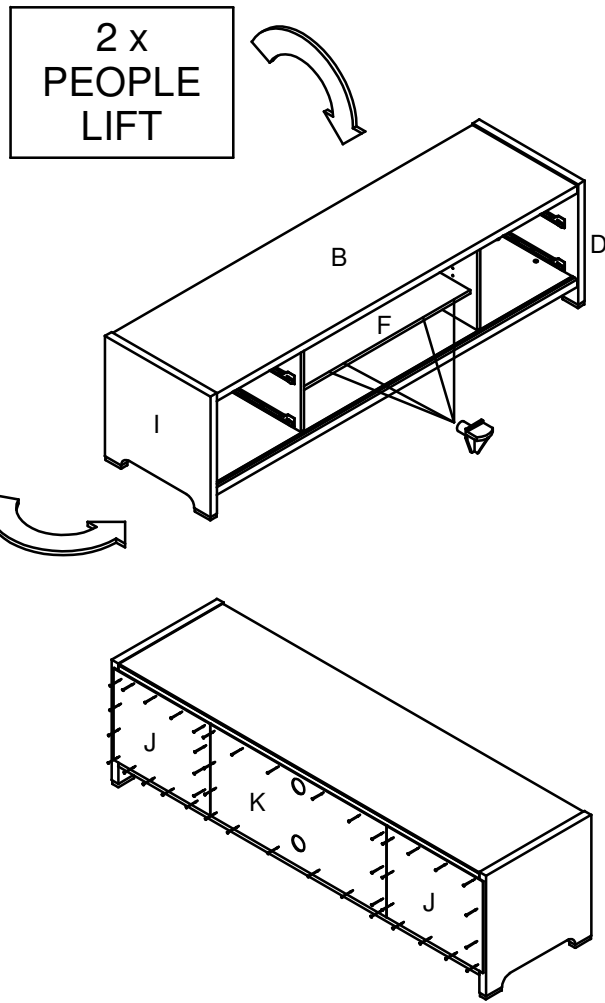

STEP 9A: PREPARE DRAWER FRONT

- 50-016
x 8
- 50-301
x 4

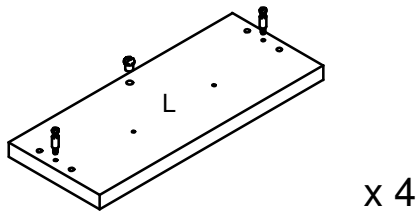

STEP 9B: ASSEMBLE DRAWER

- 50-043
x 16
- 50-136
x 8

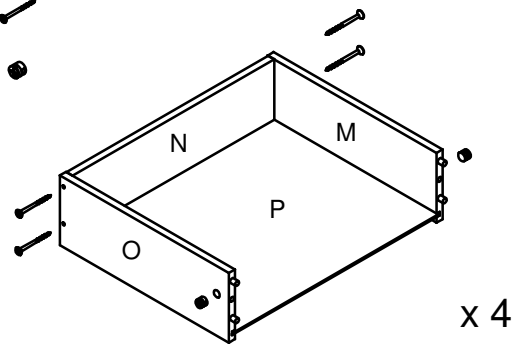

STEP 9C: ATTACH DRAWER FRONT

- 50-485
x 8
- 51-488
x 4

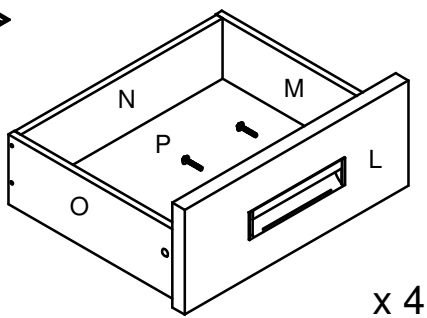

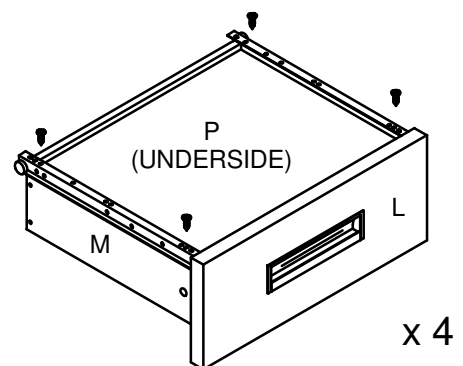

STEP 9D: ATTACH DRAWER RUNNERS

- 50-011
x 16
- 51-005
x 4



STEP 10: INSERT DRAWERS AND POSITION CAPS

- 50-140 x 2 
- 50-425 x 6 

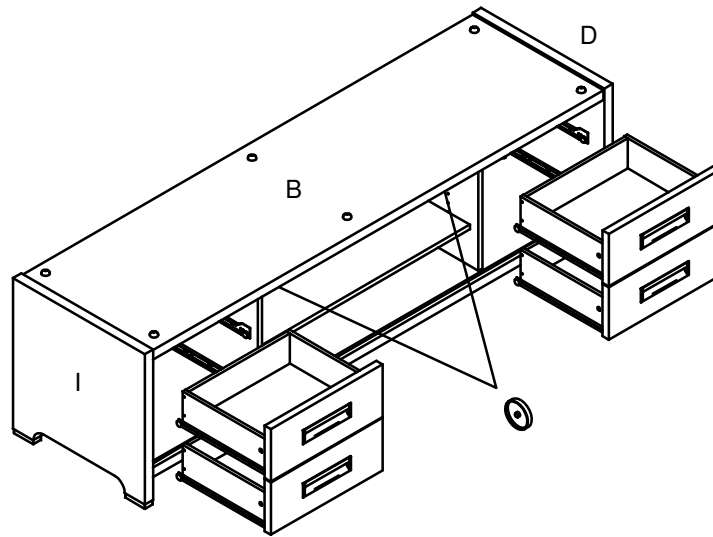

STEP 11: INSERT GLASS DOOR AND POSITION GLASS TOP

2 x
PEOPLE
LIFT

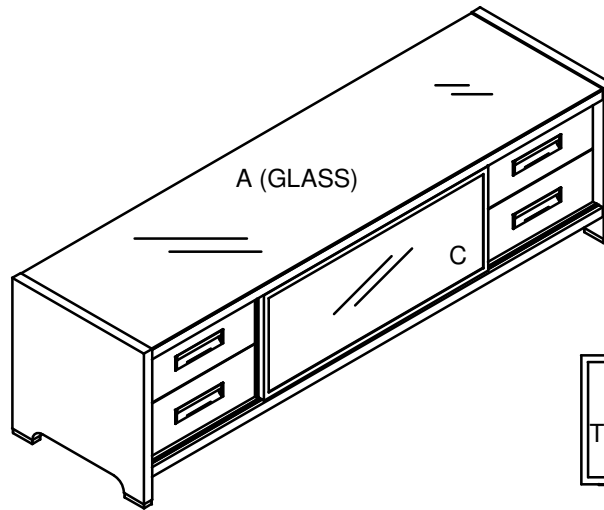

PUSH DOOR DOWN,
THEN UP INTO POSITION

SPRING WHEELS AT BASE

UNIT
COMPLETE